

Garantia

Esta luminária tem sua qualidade assegurada contra eventuais defeitos de fabricação, que porventura possam ocorrer durante o período de 1(um) ano, contados a partir da data de emissão de nota fiscal de venda ao consumidor.



Pendente



E27 Base



Lâmpada



Pintura Eletrostática



Interna



Luz direta



Quantidade por embalagem



Alumínio



Peso Líquido



Matriz

Rua Parapuã, 958 - 02831.001
Freg. do ó - São Paulo - SP - Brasil
Tel +55 (11) 2344-5861
lumivita@lumivita.com.br

M A N U A L D E I N S T A L A Ç Ã O

60088/1 Pendente Bali I

Lorem ipsum

Obrigado por comprar os produtos da Lumivita.

Pendente para lâmpada Fluor. eletrônica, consumo até 20W. Constituído em alumínio, sendo a cor preto externo e cobre na parte interna, tendo seu acabamento em pintura eletrostática, este pendente acompanha 2 metros de fio.

- Medidas aproximadas em mm.

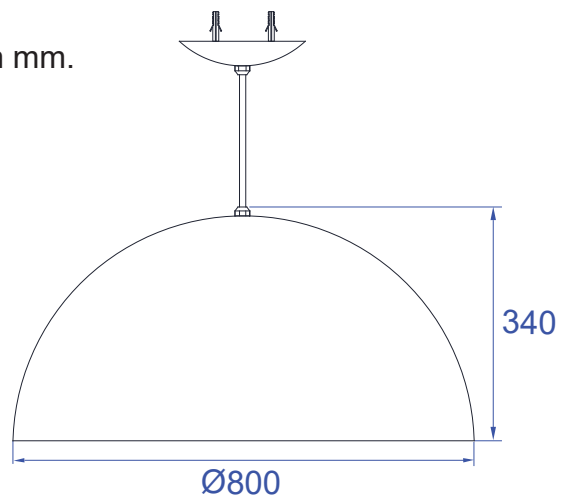

1 - Travessa

2 - Niple

3 - Canopla

4 - Cúpula

5 - Parafusos

6 - Bucha

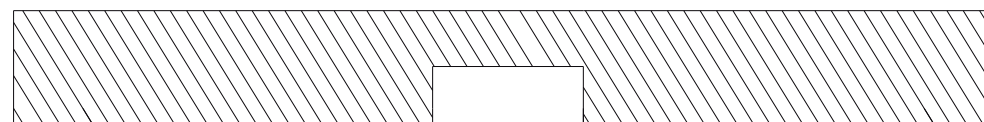
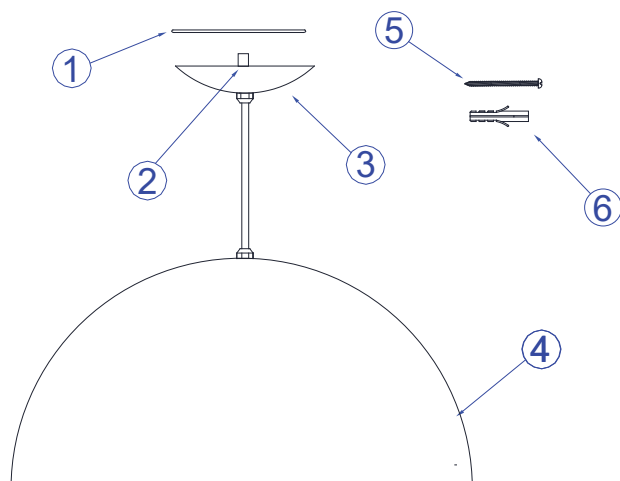

1º - Posicionar a travessa no teto. Fixando com os parafusos na bucha.

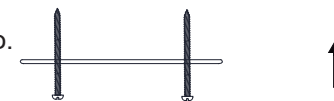

2º - Fixar a travessa no niple da canopla.

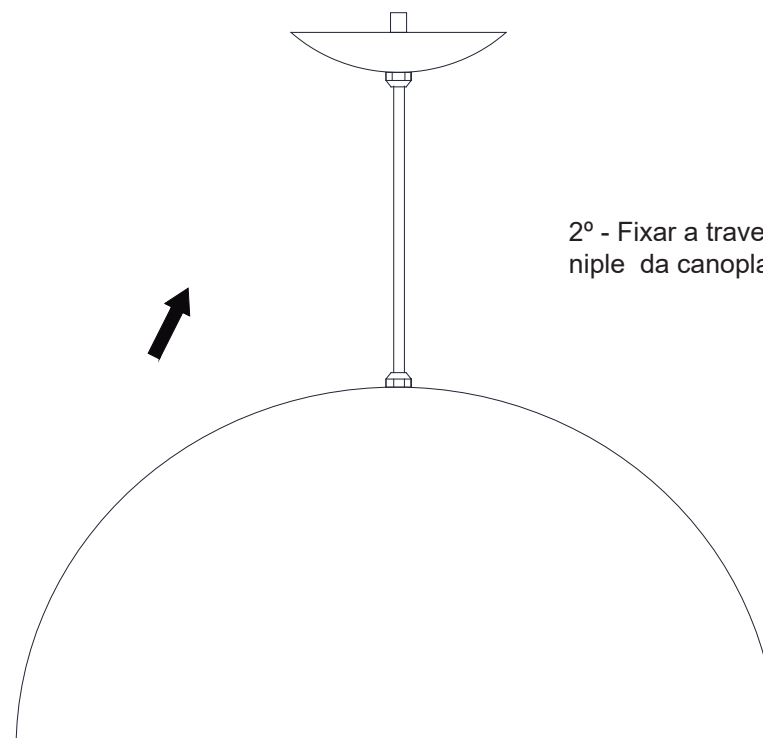

3º - Colocar a lâmpada sem forçar o soquete.

