

GARANTIA

Esta luminária tem sua qualidade assegurada contra eventuais defeitos de fabricação, que porventura possam ocorrer durante o período de 1(um) ano, contados a partir da data de emissão de nota fiscal de venda ao consumidor.

LEGENDA



Embutido



Base



Lâmpada



Pintura Eletrostática



Interna



Luz direta



Quantidade por embalagem



Alumínio



Peso Líquido



Matriz

Rua Parapuã, 958 - 02831.001
Freg. do ó - São Paulo - SP - Brasil
Tel +55 (11) 2344-5861
lumivita@lumivita.com.br

MANUAL DE INSTALAÇÃO



LUMIVITA

conceito em iluminação

10147-10190/1 Embutido Foschio II

Obrigado por comprar os produtos da Lumivita.

DESCRIÇÃO

Embutido orientável, com aro redondo de arremate. Aro em alumínio com pintura eletrostática. Tubo unicolor ou preto.

DADOS TÉCNICOS

- Medidas aproximadas em mm.

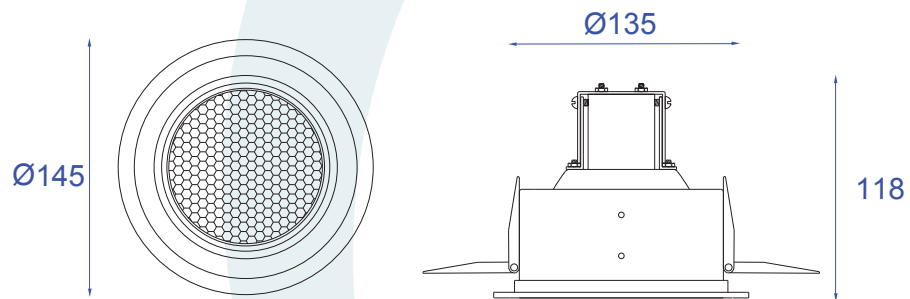

COMPONENTES

1 - Corpo do embutido

2 - Mola de fixação

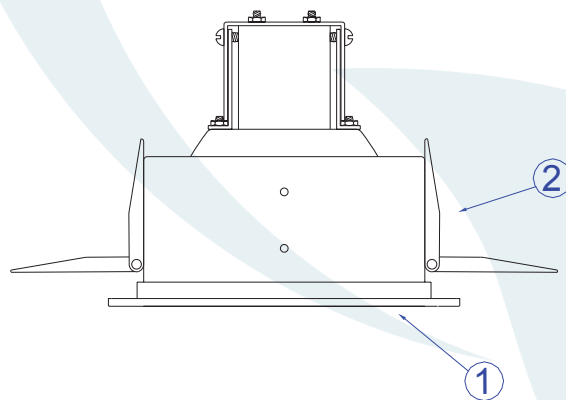

INSTALAÇÃO

